

Point-Weld Connectors in the pitch of 1.27 / 2.00 / 2.54 mm

Polyester-insulated flat conductor cables with welded-on, gold plated nickel pins, in the transition section mechanically moulded with glassfiber-reinforced polyamide. Point-weld connectors as plug-in respectively solder connectors, are, according to their pitch, available with different pin arrangements and pole numbers and combinable with all other flat conductor cable systems.

The Point-Weld System 310 is a robust, flexible plug-in or solder connection with a much higher lifetime compared to PVC-insulated connectors.

Due to the flat wires used, the connection can bear higher loading and be installed more space-savngly, but also provides a trouble-free control for flexibly arranged assembly groups as displays, pushbuttons and linear units by millions of bend-free flex cycles.

Point-weld connectors are available according to their pitch with the required arrangement of pins and mechanically moulded in the contact section by glassfiberreinforced polyamide, so that the connector is stable in pitch and becomes problem-free for flow solder method. Female connectors with screw-machined contacts for round pins $d = 0.4 - 0.56$ mm for the use of point-weld connectors are available in different pole numbers and variations. They provide highest contact stability by 4 fin contact springs of beryllium-copper with homogenous gold plating. Technical data and details for ordering can be taken from the descriptions of Systems 557 and 558, respectively.

only available in pitch 2.00 mm and 2.54 mm

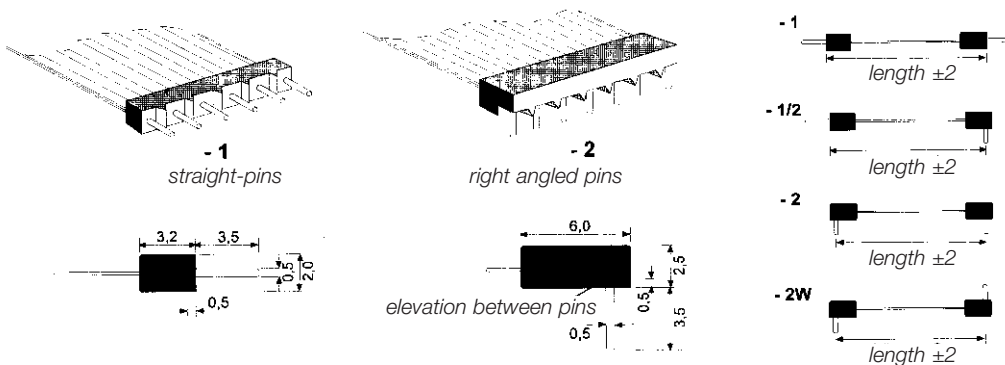

Solder Connector Systems
Point-Weld Connectors, pitch 1.27/2.00/2.54 mm



Eberhard Köpf GmbH
 Industriestrasse 34
 D-63920 Grossheubach
 Phone: +49 9371/40 04 - 0
 Telecopy: +49 9371/40 04 - 20
 E-Mail: vertrieb@adapt-elektronik.de
 Internet: www.adapt-elektronik.de

Technical Data Point-Weld Connectors

available in pitch 1.27 mm

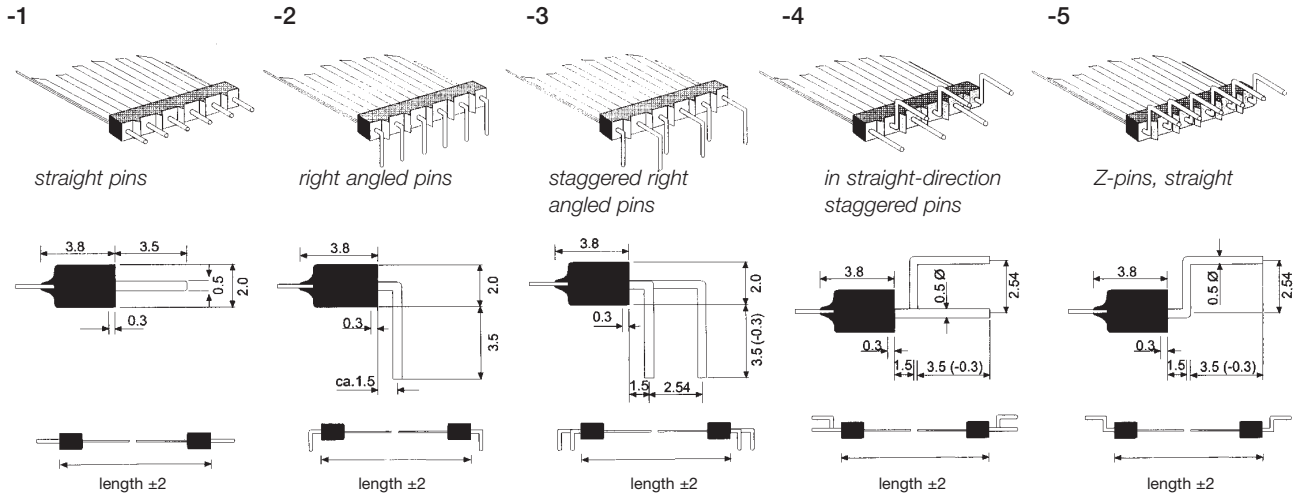

Flat conductor cable	Polyester-insulated bare copper flat conductor, alternatively tinned copper flat conductor, UL-approved		
Operating voltage	300 V		
Operating temperature	-30°C to +105°C		
Disruptive strength conductor to outside	min. 1000 V		
Disruptive strength conductor to conductor	min. 3000 V		
Pitch in mm (R)	1.27	2.00	2.54
Max. current of one conductor in A	1.5	3	3
Width of connector in mm (B)	$(N \times 1.27) + 0.5$	$(N \times 2.00) + 0.4$	$N \times 2.54$
Width of conductor in mm	0.63	1.57	1.57
Thickness of conductor in mm	0.075	0.075	0.075
Cross-section of conductor approx. in AWG	29	26	26
Thickness of insulation per side in mm	0.09		
Thickness of flat conductor cable approx. in mm	0.25		
Number of conductors (N)	1 to 65	1 to 50	1 to 50
Insulated length in mm (L)	20 or longer		
Connecting pins	Nickel, d= 0.5 mm, 0.3 my gold plated, pin ends rounded for better plugging-in		
Injection moulding in the transition section	Durethane, 30%glassfiber-reinforced polyamide UL 94-HB, 200°C temperature-resistant		
Possible pin arrangements	1 ; 2 ; 3 ; 4 ; 5 *	1 ; 2	1 ; 2

* Pin ends of fig. 3 and 4 are not rounded due to functional efficiency!

Details for ordering

310 - 100 - 15 - 2.54 - 1

